

Model: CSV

OVERVIEW

Smoke vents are designed to open automatically to provide emergency smoke and heat ventilation. Prompt venting in case of fire is essential for the safe evacuation of occupants and for effective fire-fighting conditions within a building. The smoke vent is not intended for use as general-purpose building ventilation devices. International Building Code requires smoke venting in a variety of applications including; Factory and Storage Facilities, Stages and Platforms. The following is a general instruction for installing, operating and maintaining smoke vent products. These are recommended general guidelines only. Locally accepted roofing and sealing practices and procedures should be followed to ensure the ultimate weather-ability of vents installed into various types of roofing systems.

**SHIPPING AND PACKAGING/UNPACKING**

Smoke vents will ship in covered trailer trucks. Exercise caution when cutting bands to unload smoke vents and place in an upright position on roof. *Warning: The smoke vent door is spring-loaded.*

Safety Precautions

The smoke vent doors are under spring pressure and will spring open upon release and latch actuation with the manual pull handle(s) or the fusible melt-out link.

IMPORTANT: Follow all OSHA fall protection recommendations when operating and working near smoke vents.

INSTALLATION

Ensure that the roof mounting surface is flat, square and level to avoid twisting of the smoke vent base and to ensure a proper seal. Place the smoke vent over the existing opening in the roof that has been prepared with appropriate roofing membrane, if applicable.

The roof rough opening dimensions are equal to the vent dimensions as measure from the inside curb to inside curb. For example, a 48 inch by 96 inch smoke vent will have a roof rough opening of 48 inches by 96 inches.

Curb Mount Installation

Prepare the curb using standard acceptable weatherproofing methods (i.e. butyl tape, sealant, etc.). Place the smoke vent on the curb. Fasten the smoke vent to the curb using pan-head type fasteners appropriate for the type of material the curb is constructed from. Use fasteners that will penetrate the curb a minimum of 3/4 inch. Install fasteners in the pre-drilled holes on the sides and ends of the smoke vent. Make sure the vent is centered on the curb, the distance from the outside of the curb to the fastening flange of the smoke vent should be equal all the way around the vent. Start fastening in one corner of the vent and then fasten in the opposite corner. Repeat this process until all eight fasteners are installed in the corners and then proceed to install the rest of the fasteners in the remaining pre-drilled holes. The fasteners should be installed so that they are snug to the vent flange. Over tightening may cause the vent to warp and to not function properly. See picture below for clarification.

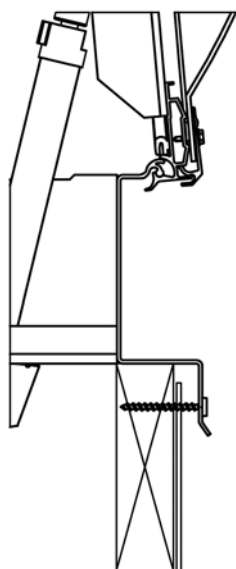

CORRECT MOUNTING

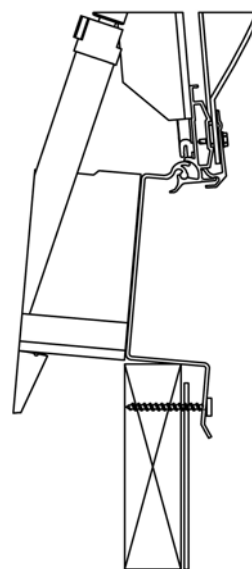

INCORRECT MOUNTING

Conduct an acceptance performance test and inspection of all smoke vents immediately following installation to establish that all operating mechanisms function properly.

OPERATION

Vents are designed and built for many years of dependable service. The assembly includes a curb and cover with a continuous extruded EPDM gasket that creates a weather resistant seal. *Warning: If interior of smoke vents are field painted, all component parts must be masked. Painted component parts may damage the smoke vents and will void the warranty.*

Field Testing

If required, test for proper operation after installation by one or more of the following:

1. Melt fusible link located inside the smoke vent using a hand-held propane torch. Replace fusible link from automatic latching mechanism, as shown below.
2. Pull internal or external manual pull handle with red vinyl grip, then close smoke vents.
3. If applicable, open vents using an electrical signal from the fire alarm.

Opening Smoke Vents

1. **Manual Operation:** Smoke vents are designed to open manually via pull handles located on the exterior and interior of the smoke vent. The internal pull cable comes with 10 feet of 1/16 inch diameter aircraft cable. If required, additional cable can be ordered.
2. **Emergency Operation:** Smoke vents are designed to open thermally when a UL 33 listed and labeled fusible link melts at its temperature rating (165°F, 212°F, 280°F, 350°F, 360°F, 370°F, 386°F, 450°F) in the event of a fire. Fusible links are easily accessed from the roof for replacement.

To replace the fusible link:

- a. Back off the nut (1) all the way to remove tension from the spring.
- b. Remove nut (2) and washer
- c. Remove screw (3), nut and washer
- d. Replace link, ensuring the proper lap joint orientation at the top
- e. Install screw (3), nut and washer
- f. Replace nut (2) and washer leaving a 1/16 inch gap so the link is free to pivot
- g. Tighten down nut (1).

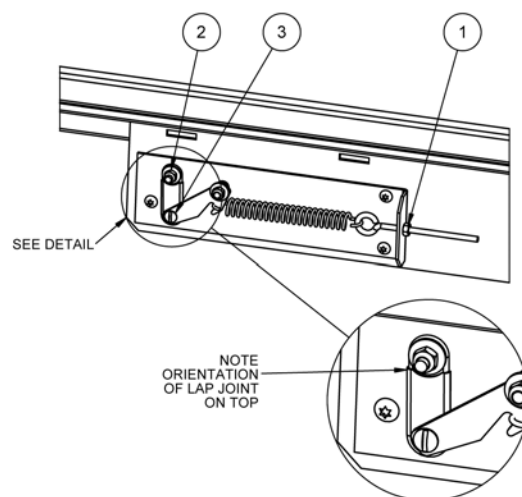

3. **OPTIONAL:** Electrical Opening: An optional Belimo actuator allows smoke vents to open electrically when a low voltage (24VDC/AC) or High Voltage (110VAC/220VAC) signal is sent to a UL listed rotary actuator to open vents in coordination with a fire alarm or sprinkler system.

Closing Smoke Vents

Smoke vent covers close manually from the exterior roof top level. The smoke vent cover is held open by a gas spring with a safety catch sleeve to ensure that the door stays open when activated. This catch sleeve must be disengaged by centering the spring within the catch sleeve so that it can slide past when the cover is being closed. Make sure when the cover is completely closed the latch engages. It will typically require two or more people to close the door, due to the force of the springs.

Caution: Follow all OSHA fall protection safety requirements regarding fall protection (i.e. OSHA 1926.500 regarding safety harnesses, tie offs points, etc.) It may be necessary to stand on top of the smoke vent door where the latch is centrally located and use one's body weight to force the doors into the fully latched position.

MAINTENANCE

Plan and schedule

Smoke Vents have a manual release device to allow direct activation to facilitate inspection, maintenance and replacement of components, such as fusible links.

Vents should be manually operated in accordance with local fire safety precautions. At a minimum, the vents should be operated annually to check proper component performance.

Fusible link inspection

- Inspect fusible links at least annually for evidence of any corrosion, stress/strain or build-up of particulate matter.
- Fusible links that have been painted must be replaced as soon as the condition is observed.
- Fusible links coated with paper dust, fiberglass hairs or similar particulate matter should be cleaned. If cleaning with air pressure does not remove such matter, replace the links or contact either the Authority Having Jurisdiction or Babcock Davis for guidance.

Cleaning recommendations

- Non-moving parts can be cleaned with a mild soap or dishwashing detergent and water solution.
- Gaskets can be cleaned with a clean, damp, lint-free cloth. *Do not apply mineral oils, vinyl dressings, or other lubricants to the gasket as they can cause the gasket to break down over time.*

Fusible link ambient temperature rating –

The fusible link should be specified with a temperature rating greater than the maximum ambient exposure temperature that will be seen at the installation. For example, an “ordinary” fusible link rated at 165 degrees F has a maximum ambient exposure temperature rating of 100 degrees F. If this fusible link is routinely exposed to ambient temperatures over 100 degrees F, it is liable to separate. Select a fusible link rated at 212 degrees F (or greater) for this type of application. See table below to find a fusible link temperature range compatible with an expected or measured ambient temperature. This is in accordance with UL guidelines.

Temperature classification	Temperature ratings		Maximum ambient temperature	
	Degrees F	(Degrees C)	Degrees F	(Degrees C)
Low	125 – 130	(51 – 54)	90	(32)
Ordinary	135 – 170	(57 – 77)	100	(38)
Intermediate	175 – 225	(79 – 107)	150	(66)
High	250 – 300	(121 – 149)	225	(107)
Extra high	325 – 375	(163 – 191)	300	(149)
Very extra high	400 – 475	(204 – 246)	375	(191)
Ultra high	500 – 575	(260 – 302)	475	(246)

Fusible link inspection – The following guidelines are recommended for facility managers or other end-users of smoke vent products.

- Inspect fusible links at least annually for evidence of corrosion, stress/strain or build-up of particulate matter.
- Fusible links that have been painted must be replaced as soon as the condition is observed.
- Fusible links coated with paper dust, fiberglass hairs or similar particulate matter should be cleaned. If cleaning with air pressure does not remove such matter, replace the links or contact either the Authority Having Jurisdiction or the fusible link manufacturer for guidance.

If any questions arise during the operation or maintenance of the products, please feel free to call technical support for assistance, 1-888-412-3726.